

ODZRAČNI VENTIL ZA OTPADNE VODE ENTLÜFTUNGSVENTILE FÜR ABWÄSSER AIR RELEASE VALVE FOR WASTE WATER

Art N°
V6-03A

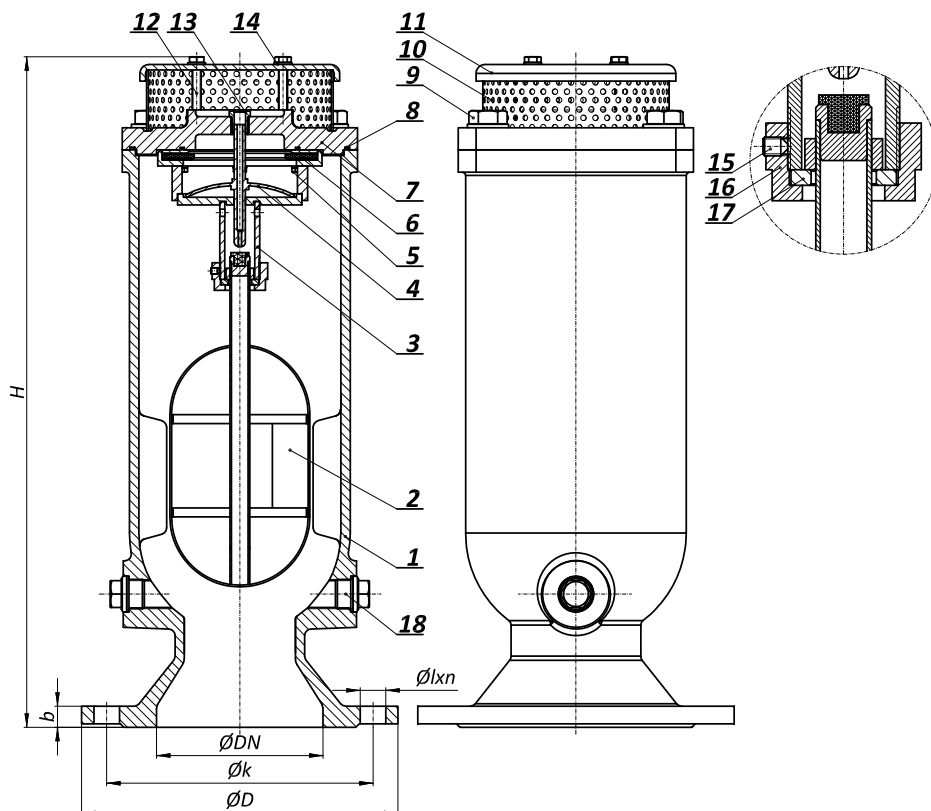

NAZIVNI PROMJER NENNWEITE NOMINAL SIZE	NAZIVNI TLAK NENNDRUCK PRESSURE RATING	PRIRUBNICE FLANSHE FLANGES EN 1092-2	VODNI ISPITNI TLAK PREMA EN 12266 WASSERPRÜFD RUCK NACH EN 12266 TEST PRESSURE ACC. TO EN 12266 bar	
			KUČIŠTE GEHAUSE BODY	ZATVORENO GESCHLOSSEN CLOSED
DN	PN bar	bar		
50-300	10	10	15	11
50-300	16	16	24	17,6



POZ TEIL PART	MATERIJAL PO EN-u WERKSTOFF NACH EN MATERIAL ACC TO EN
1	EN-GJS-400-15
2	X6CrNiMoTi 17-12-2
3	X6CrNiMoTi 17-12-2
4	X6CrNiMoTi 17-12-2
5	A4
6	NBR
7	EN-GJS-400-15
8	NBR
9	A4
10	X6CrNiMoTi 17-12-2
11	EN-GJS-400-15
12	A4
13	A4
14	A4
15	A4
16	X6CrNiMoTi 17-12-2
17	CC493K
18	A4

Ostali materijali na upit
Andere Werkstoffe auf Anfrage
Other materials on request

STANDARDNA NAMJENA: OTPADNA VODA
STANDARD VERWENDUNG: ABWASSER
STANDARD APPLICATION: WASTE WATER

MAX. RADNA TEMPERATURA: 60°C (ostalo na upit)
MAX. ARBEIT TEMPERATUR: 60°C (Andere auf Anfrage)
MAX. WORKING TEMPERATURE: 60°C (other on request)

Standardna površinska zaštita: plastificirano min. 250 mic RAL 5015
Standard beschichtung: Pulverbeschichted min. 250 mic RAL 5015
Standard coating: Fusion bonded epoxy powder min. 250 mic RAL 5015

Ostali mediji / aplikacije ili površinska zaštita na upit
Andere Medium / Verwendung oder beschichtung auf Anfrage
Other medium / application or coating on request

Prirubnice izvedene za ugradnju prema EN 1092-2 ili na zahtjev prema ostalim standardima.
Einbaufansche nach EN 1092-2 oder auf Anfrage nach andere Standard.
Installation flanges according to EN 1092-2 or on request according to other standard.

DN	H	PN 10				PN 16				b	m (kg)
		D	k	n	l	D	k	n	l		
50	680	165	125	4	19	165	125	4	19	19	32
80	680	200	160	8	19	200	160	8	19	19	32
100	680	220	180	8	19	220	180	8	19	19	34
150	680	285	240	8	23	285	240	8	23	19	37
200	680	340	295	8	23	340	295	12	23	20	128
250	680	400	350	12	23	400	355	12	28	22	136
300	680	455	400	12	23	455	410	12	28	24,5	149