

ELIPTIČNI ZASUN TIP EV PREMA EN 1171  
 ABSPERRSCHIEBER TYP EV NACH EN 1171  
 RESILIENT SEATED GATE VALVE ACCORDING TO EN 1171

Art N°  
 V2-05NT

NAZIVNI PROMJER NENNWEITE NOMINAL SIZE	NAZIVNI TLAK NENNDRUCK PRESSURE RATING	PRIRUBNICE FLANSCH FLANGES EN 1092-2	VODNI ISPITNI TLAK PREMA EN 12266 WASSERPRÜFDRUCK NACH EN 12266 TEST PRESSURE ACC. TO EN 12266 bar	
			KUČIŠTE GEHAUSE BODY	ZATVORENO GESCHLOSSEN CLOSED
DN	PN bar	bar	15	11
40 - 350	10	10	24	17,6
40 - 350	16	16		



RAL GSK  
 GSK-ID: 1238

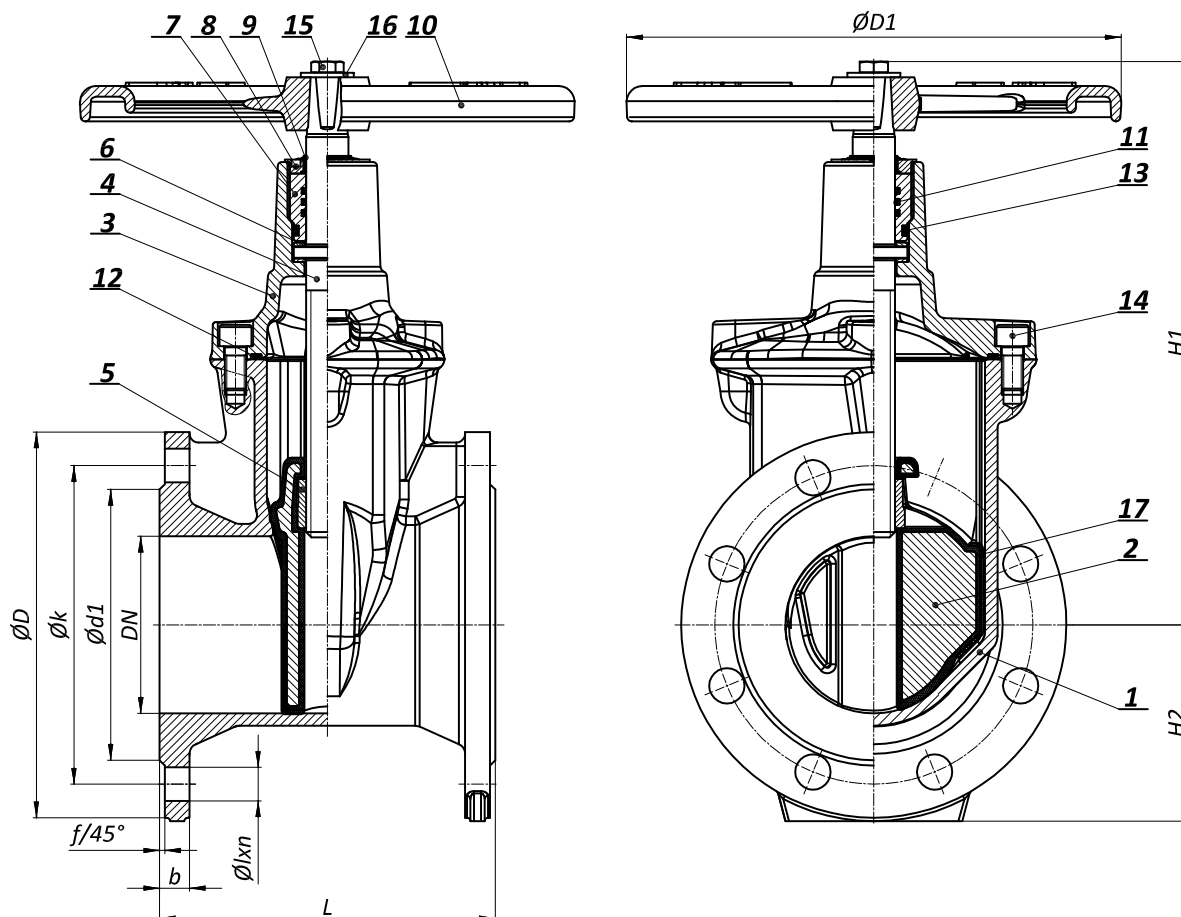

**STANDARDNA NAMJENA:** VODA, PITKA VODA, OTPADNA VODA  
**STANDARD VERWENDUNG:** WASSER, TRINKWASSER, ABWASSER  
**STANDARD APPLICATION:** WATER, POTABLE WATER, WASTE WATER

**MAX. RADNA TEMPERATURA:** 60°C (ostalo na upit)  
**MAX. ARBEIT TEMPERATUR:** 60°C (Andere auf Anfrage)  
**MAX. WORKING TEMPERATURE:** 60°C (other on request)

**Ugradna mjera / Baulängereihe / Face to face:** EN 558 SERIES 14

Standardna površinska zaštita: plastificirano min. 250 mic RAL 5015  
 Standard beschichtung: Pulverbeschichted min. 250 mic RAL 5015  
 Standard coating: Fusion bonded epoxy powder min. 250 mic RAL 5015

Ostali mediji / aplikacije ili površinska zaštita na upit  
 Andere Medium / Verwendung oder beschichtung auf Anfrage  
 Other medium / application or coating on request

Prirubnice izvedene za ugradnju prema EN 1092-2 ili na zahtjev prema ostalim standardima.  
 Einbaufansche nach EN 1092-2 oder auf Anfrage nach andere Standard.  
 Installation flanges according to EN 1092-2 or on request according to other standard.

Upravljanje ručnim kolom, produženo vreteno ili elektroprigon.  
 Handradbetätigung, Spindelverlängerung oder Elektroantrieb.  
 Handwheel operation, ext. spindle or el. actuator.

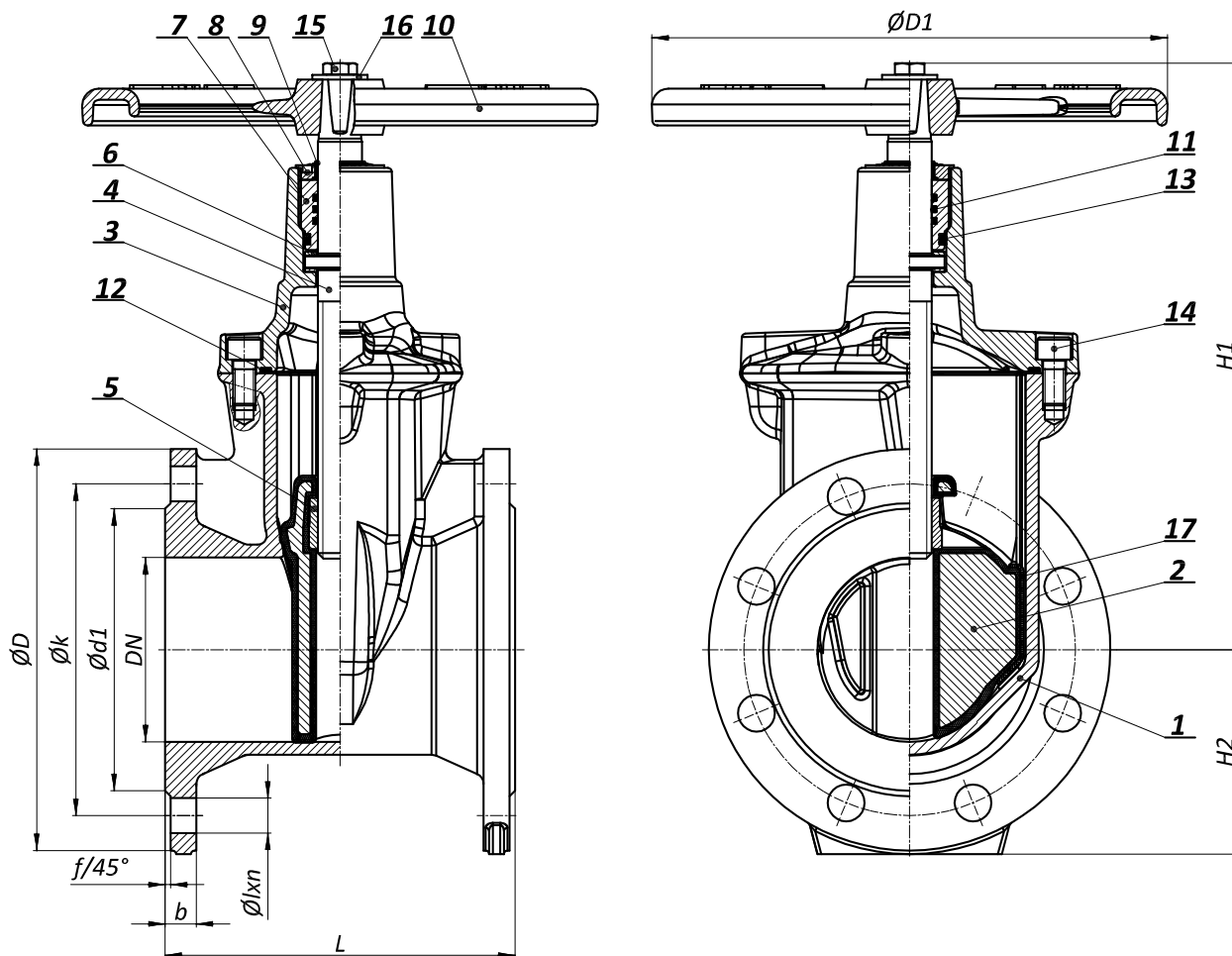

POZICIJA POSITION POSITION	NAZIV POZICIJE	TEIL	PART	MATERIJAL MATERIAL MATERIAL
1	Kučište	Gehäuse	Body	EN-GJS-400-15
2	Klin	Keil	Wedge	EN-GJS-400-15 + EPDM
3	Kapa	Haube	Bonnet	EN-GJS-400-15
4	Vreteno	Spindel	Spindle	X20Cr13
5	Matica vretena	Spindelmutter	Spindle Nut	CW612N
6	Klizni prsten	Schiebe ring	Sliding ring	Poliacetal
7	Brtvena puškica	Dichtungbuchse	Sealing Bush	CW612N
8	Poklopac brvene puškice	Dichtungbuchse Deckel	Sealing Bush Cover	Poliamid
9	Brisač	Racieur	Wiper	EPDM
10	Ručno kolo	Handrad	Hand Wheel	EN-GJS-400-15
11	"O" brtva	"O" Ring	"O" Ring	EPDM
12	"O" brtva	"O" Ring	"O" Ring	EPDM
13	"O" brtva	"O" Ring	"O" Ring	EPDM
14	Vijak	Schraube	Screw	A2
15	Vijak	Schraube	Screw	A2
16	Podložna pločica	Schaube	Washer	A2
17	Vodilica klina	Keilführungen	Wedge Guideline	Poliamid

\* standardni materijali  
\* ostali materijali na upit

\* Standardwerkstoffe  
\* Andere Werkstoffe auf Anfrage

\* standard materials  
\* other materials on request

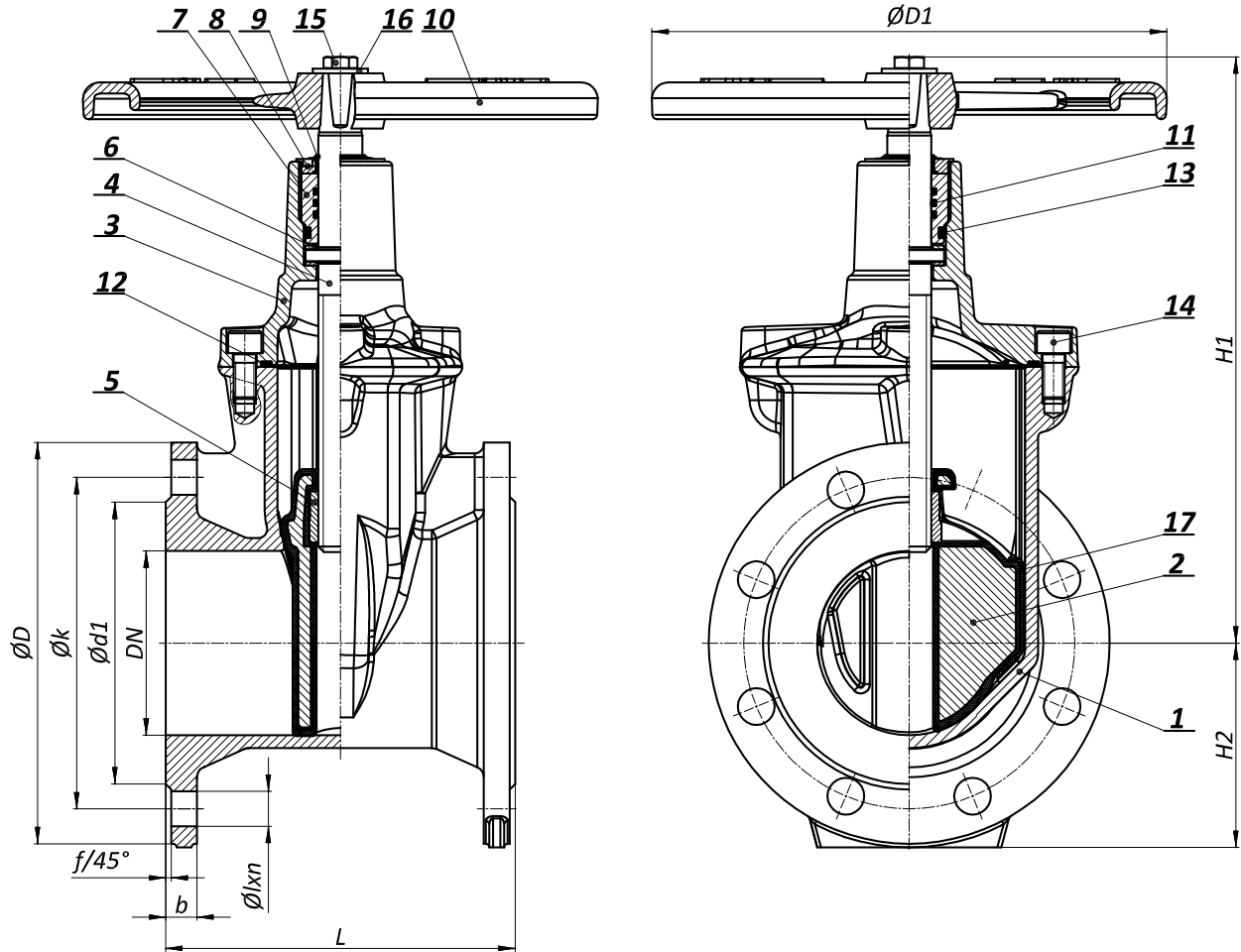

DN	L	H <sub>1</sub>	PN10	PN16	PN 10						PN 16						f	D <sub>1</sub>	Br. okr. / Otvaranje Umdr. / Hub. Turns / lift	m (kg)
			H <sub>2</sub>	D	k	d <sub>1</sub>	l	n	b	D	k	d <sub>1</sub>	l	n	b					
40	140	247	80	80	150	110	84	19	4	19	150	110	84	19	4	19	3	180	12	10
50	150	247	87,5	87,5	165	125	99	19	4	19	165	125	99	19	4	19	3	180	12	11,5
60	160	270,4	92,5	92,5	175	135	108	19	4	19	175	135	108	19	4	19	3	250	13	15
65	170	270,4	97,5	97,5	185	145	118	19	4	19	185	145	118	19	4	19	3	250	13	15,5
80	180	288	105	105	200	160	132	19	8	19	200	160	132	19	8	19	3	250	16	18
100	190	319	115	115	220	180	156	19	8	19	220	180	156	19	8	19	3	280	20	21
150	210	417	147,5	147,5	285	240	211	23	8	19	285	240	211	23	8	19	3	320	31	37
200	230	493,5	180	180	340	295	266	23	8	20	340	295	266	23	12	20	3	360	33	63
250	250	626	207,5	212,5	395	350	319	23	12	22	405	355	319	28	12	22	3	400	43	92
300	270	690	232,5	240	445	400	370	23	12	24,5	460	410	370	28	12	24,5	4	500	51	136
350	290	811	262,5	270	505	460	429	23	16	24,5	520	470	429	28	16	26,5	4	500	59	211

\* ostali profili na upit

\* andere Nennweite auf Anfrage

\* other nominal sizes on request