

POZICIJA POSITION POSITION	NAZIV POZICIJE	TEIL	PART	MATERIJAL MATERIAL MATERIAL
1	Kučište	Gehäuse	Body	EN-GJS-400-15
2	Klin	Keil	Wedge	EN-GJS-400-15 + EPDM
3	"O" brtva	"O" Ring	"O" Ring	EPDM
4	Matica vretena	Spindelmutter	Spindle Nut	CW612N
5	Kapa	Haube	Bonnet	EN-GJS-400-15
6	Vreteno	Spindel	Spindle	X20Cr13
7	Brtvena puškica	Dichtungbuchse	Sealing Bush	CW612N
8	Brisač	Racieur	Wiper	EPDM
9	Poklopac brvene puškice	Dichtungbuchse Deckel	Sealing Bush Cover	Poliamid
10	Ručno kolo	Handrad	Hand Wheel	EN-GJS-400-15
11	Podložna pločica	Schaube	Washer	A2
12	Vijak	Schraube	Screw	A2
13	"O" brtva	"O" Ring	"O" Ring	EPDM
14	"O" brtva	"O" Ring	"O" Ring	EPDM
15	Klizni prsten	Schiebe ring	Sliding ring	Ms
16	Vijak	Schaube	Screw	A2

\* standardni materijali  
\* ostali materijali na upit

\* Standardwerkstoffe  
\* Andere Werkstoffe auf Anfrage

\* standard materials  
\* other materials on request

NAZIVNI PROMJER NENNWEITE NOMINAL SIZE	NAZIVNI TLAK NENNDRUCK PRESSURE RATING	PRIRUBNICE FLANSHE FLANGES EN 1092-2	VODNI ISPITNI TLAK PREMA EN 12266 WASSERPRÜFDRUCK NACH EN 12266 TEST PRESSURE ACC. TO EN 12266 bar	
			KUČIŠTE GEHAUSE BODY	ZATVORENO GESCHLOSSEN CLOSED
DN	PN bar	bar		
50 – 500	10	10	15	11
50 – 500	16	16	24	17,6
50 – 400	25	25	37,5	27,5

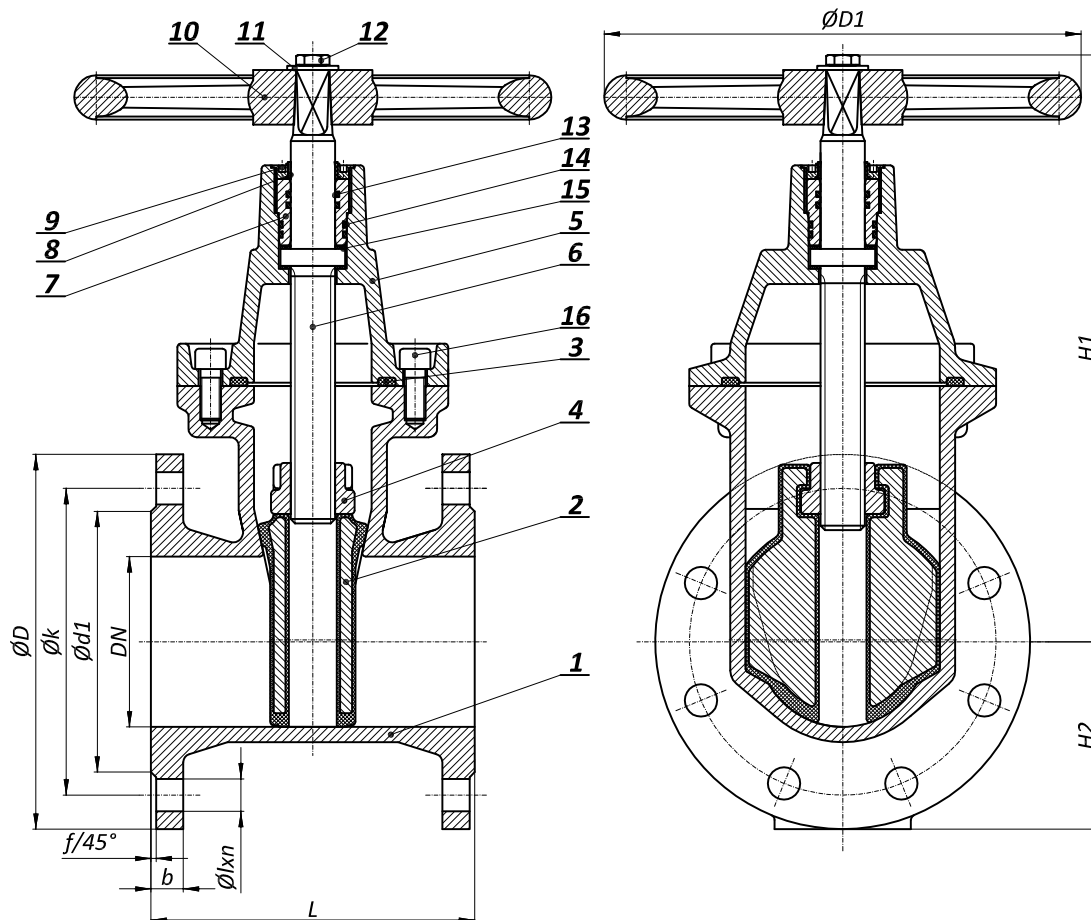

**STANDARDNA NAMJENA:** VODA, PITKA VODA, OTPADNA VODA  
**STANDARD VERWENDUNG:** WASSER, TRINKWASSER, ABWASSER  
**STANDARD APPLICATION:** WATER, POTABLE WATER, WASTE WATER

**MAX. RADNA TEMPERATURA:** 60°C (ostalo na upit)  
**MAX. ARBEIT TEMPERATURE:** 60°C (Andere auf Anfrage)  
**MAX. WORKING TEMPERATURE:** 60°C (other on request)

**Ugradna mjera / Baulängereihe / Face to face:** EN 558 SERIES 14

Standardna površinska zaštita: plastificirano min. 250 mic RAL 5015  
Standard beschichtung: Pulverbeschichted min. 250 mic RAL 5015  
Standard coating: Fusion bonded epoxy powder min. 250 mic RAL 5015

Ostali mediji / aplikacije ili površinska zaštita na upit  
Andere Medium / Verwendung oder beschichtung auf Anfrage  
Other medium / application or coating on request

Prirubnice izvedene za ugradnju prema EN 1092-2 ili na zahtjev prema ostalim standardima.  
Einbaufansche nach EN 1092-2 oder auf Anfrage nach andere Standard.  
Installation flanges according to EN 1092-2 or on request according to other standard.

Upravljanje ručnim kolom. Na zahtjev hidrauličko ili pneumatičko upravljanje, elektromotorni pogon.  
Handradbetätigung. Auf Anfrage hydraulische oder pneumatische Steuerung, Elektroantrieb.  
Hand wheel operation. On request hydraulic or pneumatical actuation, electric actuator.

DN	L	H <sub>1</sub>	PN10	PN16	PN 10						PN 16						f	D <sub>1</sub>	Br. okr. / Otvaranje Umdr. / Hub. Turns / lift	m (kg)
			H <sub>2</sub>		D	k	d <sub>1</sub>	l	n	b	D	k	d <sub>1</sub>	l	n	b				
50	150	230	87,5	87,5	165	125	99	19	4	19	165	125	99	19	4	19	3	180	18	13
65	170	240	97,5	97,5	185	145	118	19	4/8	19	185	145	118	19	4/8	19	3	225	18	20
80	180	280	105	105	200	160	132	19	8	19	200	160	132	19	8	19	3	225	21	24,5
100	190	330	115	115	220	180	156	19	8	19	220	180	156	19	8	19	3	280	24	32,5
125	200	390	130	130	250	210	184	19	8	19	250	210	184	19	8	19	3	320	30	40,5
150	210	460	147,5	147,5	285	240	211	23	8	19	285	240	211	23	8	19	3	320	36	53
200	230	550	180	180	340	295	266	23	8	20	340	295	266	23	12	20	3	360	38	83
250	250	660	207,5	212,5	395	350	319	23	12	22	405	355	319	28	12	22	3	400	47	120
300	270	760	232	240	445	400	370	23	12	24,5	460	410	370	28	12	24,5	4	500	56	168
350	290	822	262,5	270	505	460	429	23	16	24,5	520	470	429	28	16	26,5	4	500	56	240
400	310	910	292,5	300	565	515	480	28	16	24,5	580	525	480	31	16	28	4	640	62	336
500	350	1200	345	367,5	670	620	582	28	20	26,5	715	650	609	34	20	31,5	4	720	68	603

\* ostali profili na upit

\* andere Nennweite auf Anfrage

\* other nominal sizes on request

DN	L	H <sub>1</sub>	H <sub>2</sub>	PN 25								D <sub>1</sub>	Br. okr. / Otvaranje Umdr. / Hub. Turns / lift	m (kg)
				D	k	d <sub>1</sub>	l	n	b	f				
50	150	230	87,5	165	125	99	19	4	19	3	180	18	13	
65	170	240	97,5	185	145	118	19	8	19	3	225	18	20	
80	180	280	105	200	160	132	19	8	19	3	225	21	24,5	
100	190	330	122,5	235	190	156	23	8	19	3	280	24	32,5	
125	200	390	140	270	220	184	28	8	19	3	320	30	40,5	
150	210	460	155	300	250	211	28	8	20	3	320	36	53	
200	230	550	190	360	310	274	28	12	22	3	360	38	83	
250	250	660	222,5	425	370	330	31	12	24,5	3	400	47	120	
300	270	760	252,5	485	430	389	31	16	27,5	4	500	56	168	
400	310	910	320	620	550	503	37	16	32	4	640	62	370	

\* ostali profili na upit

\* andere Nennweite auf Anfrage

\* other nominal sizes on request



ELIPTIČNI ZASUN TIP EV - PRIKLUČNI NASTAVCI ZA ROTACIONE ZAGONE  
 ABSPERRSCHIEBER TYP EV - ANSCHLUFORM NACH DREHANTRIEB  
 RESILIENT SEATED GATE VALVE - OUTPUT DRIVE TYPES ACCORDING TO ACTUATOR

Art N°  
V2-05

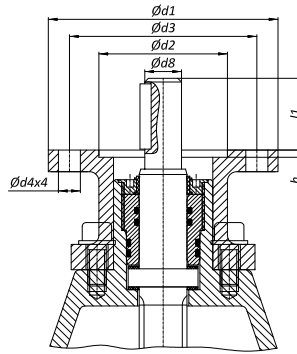

PN 10

DN	Aksijalna sila Axialkraft Axial force	Okretni moment Drehmoment Torque	Okretaj / hod Umdrehung/Hub Turns / lift	Vrijeme zatvaranja Schliesszeit Closing time	Priključak Anschluss Connection	Mjere priključnog nastavka Anschlußformmaße Output drive type dimensions							Rotacioni zagon Drehantrieb Actuator
	kN	Nm		s		ISO 5210	d <sub>1</sub>	d <sub>2</sub>	d <sub>3</sub>	d <sub>4</sub>	h	d <sub>8</sub>	l <sub>1</sub>
65	4,5	24	18	12	F 07	90	55	70	10	3	16	35	SA 07.2
80	6,4	28	21	14	F 07	90	55	70	10	3	16	35	SA 07.6
100	9,5	40	24	17	F 07	90	55	70	10	3	16	35	SA 07.6
125	11,1	50	30	20	F 07	90	55	70	10	3	16	35	SA 07.6
150	13	60	36	40	F 10	125	70	102	12	3	20	45	SA 10.2
200	17,8	120	38	54	F 14	175	100	140	18	4	30	65	SA 10.2
250	24	200	44	78	F 14	175	100	140	18	4	30	65	SA 14.6
300	31,4	250	56	90	F 14	175	100	140	18	4	30	65	SA 14.6
400	50,8	350	62	126	F 14	175	100	140	18	4	30	65	SA 14.6
500	68,8	500	272	259	F 14	175	100	140	18	5	30	65	R1:4+SA14.2

PN 16

DN	Aksijalna sila Axialkraft Axial force	Okretni moment Drehmoment Torque	Okretaj / hod Umdrehung/Hub Turns / lift	Vrijeme zatvaranja Schliesszeit Closing time	Priključak Anschluss Connection	Mjere priključnog nastavka Anschlußformmaße Output drive type dimensions							Rotacioni zagon Drehantrieb Actuator
	kN	Nm		s		ISO 5210	d <sub>1</sub>	d <sub>2</sub>	d <sub>3</sub>	d <sub>4</sub>	h	d <sub>8</sub>	l <sub>1</sub>
65	4,5	27	18	12	F 07	90	55	70	10	3	16	35	SA 07.2
80	6,4	40	21	14	F 07	90	55	70	10	3	16	35	SA 07.6
100	9,5	65	24	17	F 10	125	70	102	12	3	20	45	SA 10.2
125	11,1	70	30	20	F 10	125	70	102	12	3	20	45	SA 10.2
150	13	100	36	40	F 10	125	70	102	12	3	20	45	SA 10.2
200	17,8	160	38	54	F 14	175	100	140	18	4	30	65	SA 14.2
250	24	250	44	78	F 14	175	100	140	18	4	30	65	SA 14.6
300	31,4	325	56	90	F 14	175	100	140	18	4	30	65	SA 14.6
400	50,8	550	248	126	F 14	175	100	140	18	5	40	65	R1:4+SA 14.2
500	68,8	720	272	259	F 14	175	100	140	18	5	40	65	R1:4+SA14.2

PN 25

DN	Aksijalna sila Axialkraft Axial force	Okretni moment Drehmoment Torque	Okretaj / hod Umdrehung/Hub Turns / lift	Vrijeme zatvaranja Schliesszeit Closing time	Priključak Anschluss Connection	Mjere priključnog nastavka Anschlußformmaße Output drive type dimensions							Rotacioni zagon Drehantrieb Actuator
	kN	Nm		s		ISO 5210	d <sub>1</sub>	d <sub>2</sub>	d <sub>3</sub>	d <sub>4</sub>	h	d <sub>8</sub>	l <sub>1</sub>
65	5,4	33	18	12	F07	90	55	70	10	3	16	35	SA 07.6
80	7,7	48	21	14	F07	90	55	70	10	3	16	35	SA 07.6
100	11,5	78	24	17	F10	125	125	102	12	3	20	45	SA 10.2
125	13,3	84	30	20	F10	125	125	102	12	3	20	45	SA 10.2
150	15,6	125	36	40	F14	175	175	140	18	4	30	65	SA 14.2
200	21,3	235	38	54	F14	175	175	140	18	4	30	65	SA 14.2
250	28,8	300	44	78	F14	175	175	140	18	4	30	65	SA 14.6
300	37,6	390	56	90	F14	175	175	140	18	4	30	65	SA 14.6