

OKRUGLI ZASUN S JARMOM PREMA EN 1171
 RUNDABSPERRSCHIEBER MIT AUSENLIEGENDE SPINDLE NACH EN 1171
 GATE VALVE WITH ROUND BODY AND RISING SPINDLE ACC. TO EN 1171

Art N°
 V3-02



GSK-ID: 1238

NAZIVNI PROMJER NENNWEITE NOMINAL SIZE	NAZIVNI TLAK NENNDRUCK PRESSURE RATING	PRIRUBNICE FLANSHE FLANGES EN 1092-2	VODNI ISPITNI TLAK PREMA EN 12266 WASSERPRÜFD RUCK NACH EN 12266 TEST PRESSURE ACC. TO EN 12266 bar	
			KUČIŠTE GEHAUSE BODY	ZATVORENO GESCHLOSSEN CLOSED
DN	PN bar	bar		
40 – 600	40	40	60	44
40 – 1000	25	25	37,5	27,5
40 – 1000	16	16	24	17,5
40 – 1000	10	10	15	11

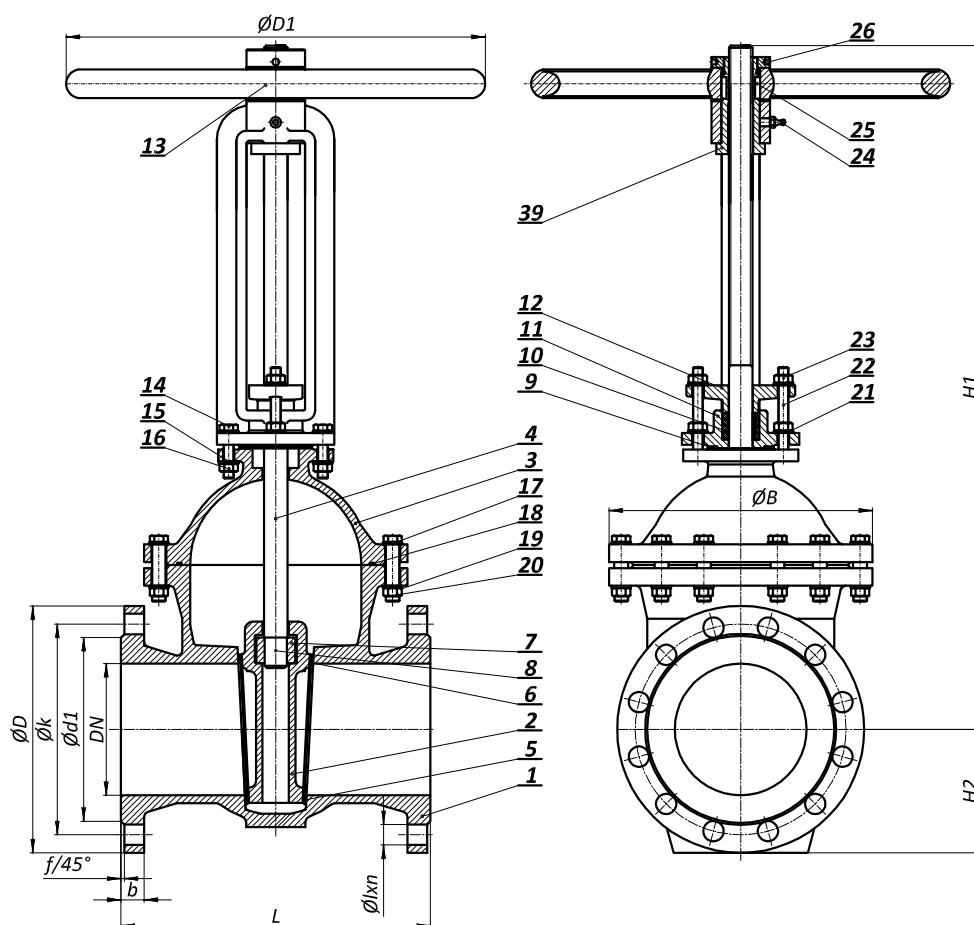

STANDARDNA NAMJENA: VODA, PITKA VODA, OTPADNA VODA
STANDARD VERWENDUNG: WASSER, TRINKWASSER, ABWASSER
STANDARD APPLICATION: WATER, POTABLE WATER, WASTE WATER

MAX. RADNA TEMPERATURA: 60°C (ostalo na upit)
MAX. ARBEIT TEMPERATUR: 60°C (Andere auf Anfrage)
MAX. WORKING TEMPERATURE: 60°C (other on request)

Ugradna mjera / Baulängereihe / Face to face: DIN 3202 SERIES F15

Standardna površinska zaštita: plastificirano min. 250 mic RAL 5015
Standard beschichtung: Pulverbeschichted min. 250 mic RAL 5015
Standard coating: Fusion bonded epoxy powder min. 250 mic RAL 5015

Ostali mediji / aplikacije ili površinska zaštita na upit
Andere Medium / Verwendung oder beschichtung auf Anfrage
Other medium / application or coating on request

Prirubnice izvedene za ugradnju prema EN 1092-2 ili na zahtjev prema ostalim standardima.
Einbaufansche nach EN 1092-2 oder auf Anfrage nach andere Standard.
Installation flanges according to EN 1092-2 or on request according to other standard.

Upravljanje ručnim kolom. Na zahtjev elektromotorni pogon, reduktor, produženo vreteno, hidrauličko ili pneumatsko upravljanje.
Handradbetätigung. Auf Anfrage Elektroantrieb, Reduktionsgetriebe, spindel verlängerung, hydraulische oder pneumatische Steuerung.
Handwheel operation. On request electric actuator, gearbox, extension spindle, hydraulic or pneumatical actuation

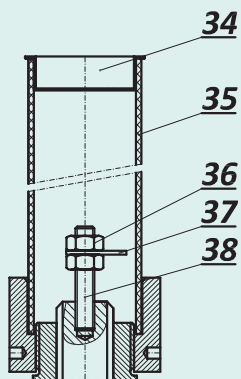
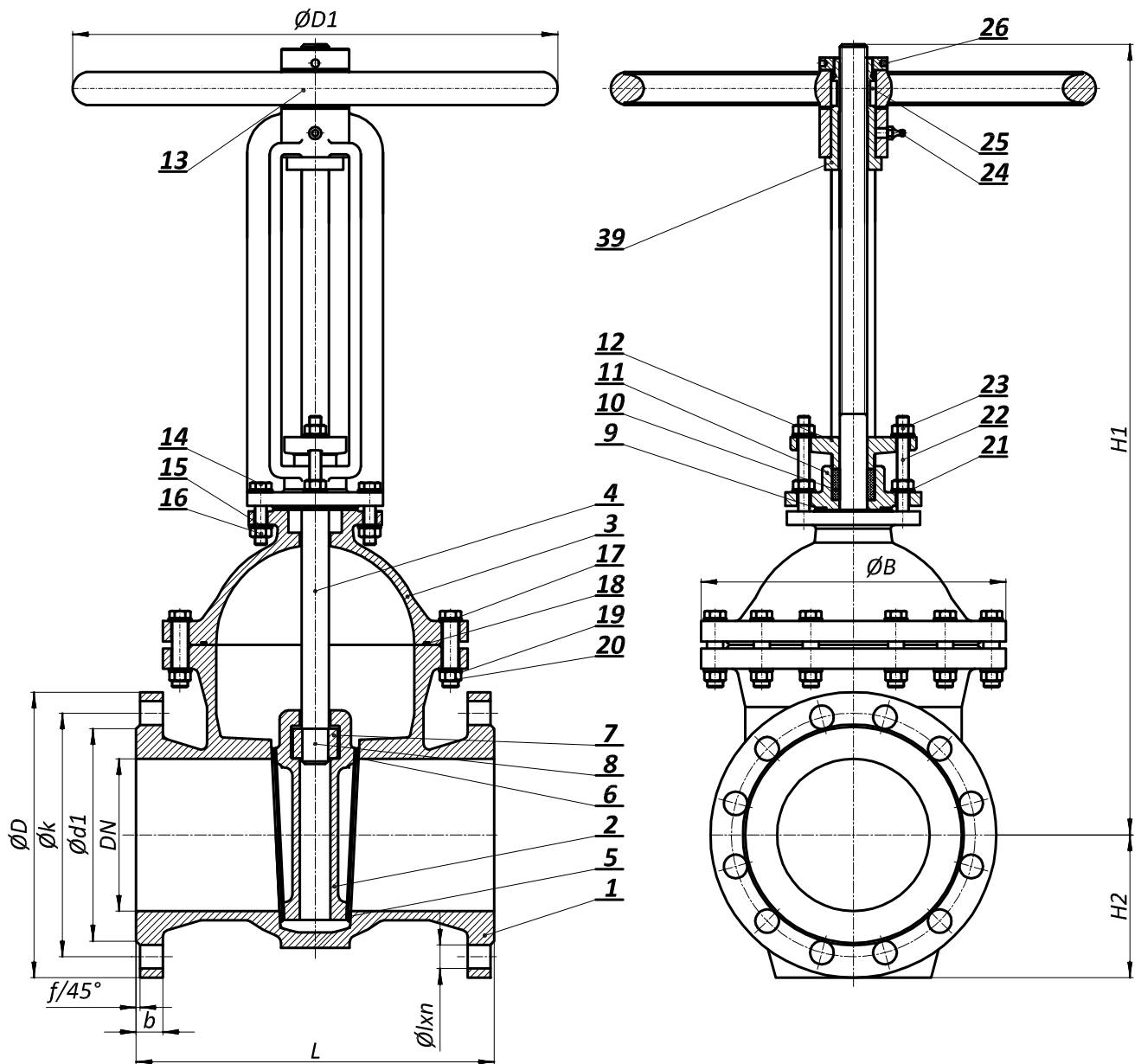

POKAZIVAČ OTVORENOSTI
ANZEIGEWERK
POSITION INDICATOR

BRTVLJENJE
ABDICHTUNG
SEALING

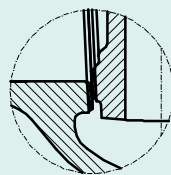

X15CrNiMn 18-8 / X15CrNiMn 18-8
CC480K / CC480K

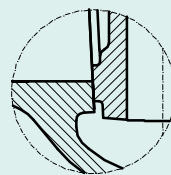

EN-GJS-400-15 /
EN-GJS-400-15

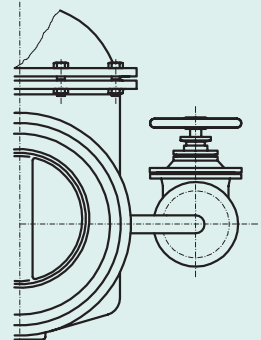

MIMOVOD
UMFÜHRUNG
BYPASS

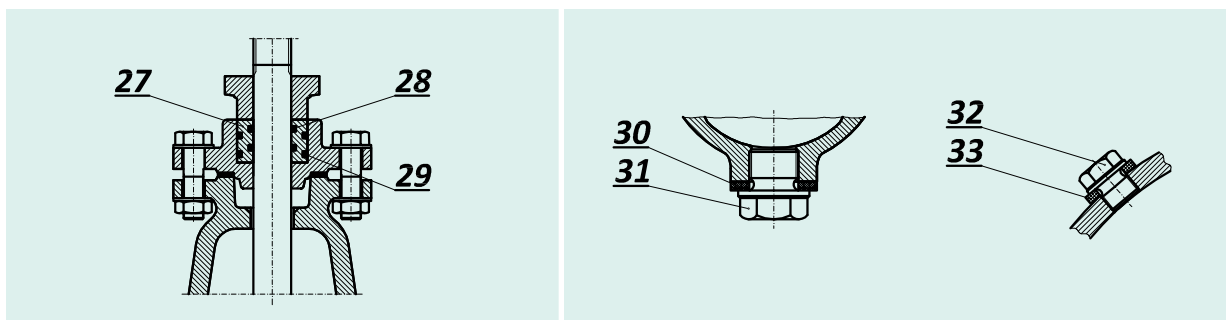

POZICIJA POSITION POSITION	NAZIV POZICIJE	TEIL	PART	MATERIJAL MATERIAL MATERIAL
1	Kučište	Gehäuse	Body	EN-GJS-400-15
2	Klin	Keil	Wedge	EN-GJS-400-15
3	Kapa	Haube	Bonnet	EN-GJS-400-15
4	Vreteno	Spindel	Spindle	X20Cr13
5	Prsten kućišta	Gehäusesitzring	Body Seat Ring	CC480K
6	Prsten klina	Keilsitzring	Wedge Seat Ring	CC480K
7	Matica vretena	Spindelmutter	Spindle nut	CC483K
8	Zatik	Stift	Pin	X17CrNi 16-2
9	Plosnata brtva	Dichtung	Gasket	It / EPDM
10	Pletenica	Stopfbuchpackung	Stuffing Box Packing	PTFE
11	Jaram	Ständer	Stand	EN-GJS-400-15
12	Jednostruka brtvenica	Stopfbuchbrille	Stuffing Box	EN-GJS-400-15
13	Ručno kolo	Handrad	Hand Wheel	EN-GJS-400-15
14	Vijak	Schraube	Screw	8.8 galv.
15	Podložna pločica	Schaube	Washer	galv.
16	Matica	Mutter	Nut	8 galv.
17	Vijak	Schraube	Screw	8.8 galv.
18	"O" brtva	"O" Ring	"O" Ring	EPDM
19	Podložna pločica	Schaube	Washer	galv.
20	Matica	Mutter	Nut	8 galv.
21	Podložna pločica	Schaube	Washer	galv.
22	Navojna šipka	Gewindestange	Threaded rod	A2
23	Matica	Mutter	Nut	8 galv.
24	Mazalica	Schmiernippel	Lubricating Nipple	Ms
25	Pero	Passfeder	Parallel Key	C45E
26	Matica	Mutter	Nut	CC483K
27	Brtvenica	Dichtungsbuchse	Sealing Bush	CC493K
28	"O" brtva	"O" Ring	"O" Ring	EPDM
29	"O" brtva	"O" Ring	"O" Ring	EPDM
30	Brtva čepa za odmuljivanje	Dichtung	Gasket	Cu
31	Čep za odmuljivanje	Entleerungsschraube	Drain Plug Screw	A4
32	Brtva čepa za odzračivanje	Dichtung	Gasket	Cu
33	Čep za odzračivanje	Entlüftungsschraube	Air Release Screw	A4
34	Čep	Deckel	Cover	PE
35	Zaštitna cijev	Schutzrohr	Protection Pipe	Polikarbonat
36	Matica	Mutter	Nut	8 galv.
37	Pokazivač položaja	Anzeigewerk	Position Indicator	8.8 galv.
38	Navojna šipka	Gewindestange	Threaded Rod	A2
39	Provodna matica	Spindelmutter	Spindle nut	CC483K

* standardni materijali
* ostali materijali na upit

* Standardwerkstoffe
* Andere Werkstoffe auf Anfrage

* standard materials
* other materials on request

DN	L	H ₁		PN10	PN16	B	PN 10						PN 16						f	D ₁	Br. okr. / Otvoranje Umdr. / Hub. Turns / lift	m
		Zatvoreno Geschlossen Closed	Otvoreno Offen Open	H ₂			D	k	d ₁	l	n	b	D	k	d ₁	l	n	b				
40	240	420	480	80	80	160	150	110	84	19	4	19	150	110	84	19	4	19	3	200	11	23
50	250	440	510	87,5	87,5	180	165	125	99	19	4	19	165	125	99	19	4	19	3	225	13	30
65	270	490	580	97,5	97,5	215	185	145	118	19	4/8	19	185	145	118	19	4/8	19	3	280	18	45
80	280	510	610	105	105	235	200	160	132	19	8	19	200	160	132	19	8	19	3	280	21	50
100	330	600	720	115	115	280	220	180	156	19	8	19	220	180	156	19	8	19	3	320	25	72
125	360	705	850	130	130	315	250	210	184	19	8	19	250	210	184	19	8	19	3	360	24	111
150	390	775	950	147,5	147,5	340	285	240	211	23	8	19	285	240	211	23	8	19	3	360	28	125
200	460	970	1200	180	180	420	340	295	266	23	8	20	340	295	266	23	12	20	3	400	37	220
250	530	1165	1440	207,5	212,5	500	395	350	319	23	12	22	405	355	319	28	12	22	3	500	39	270
300	630	1250	1600	232	240	580	445	400	370	23	12	24,5	460	410	370	28	12	24,5	4	640	46	430
350	690	1390	1780	262,5	270	620	505	460	429	23	16	24,5	520	470	429	28	16	26,5	4	640	54	530
400	750	1630	2070	292,5	300	690	565	515	480	28	16	24,5	580	525	480	31	16	28	4	720	54	730
500	880	1900	2430	345	367,5	840	670	620	582	28	20	26,5	715	650	609	34	20	31,5	4	800	59	1250
600	1000	2200	2850	400	430	980	780	725	682	31	20	30	840	770	720	37	20	36	5	800	72	1830
700	1130	2500	3250	457,5	465	1060	895	840	794	31	24	32,5	910	840	794	37	24	39,5	5	800	75	2420
800	1250	2900	3750	517,5	522,5	1200	1015	950	901	34	24	35	1025	950	901	41	24	43	5	900	86	3400
1000	1500	3420	4450	625	637,5	1460	1230	1160	1112	37	28	40	1255	1170	1112	44	28	50	5	900	105	5280

* ostali profili na upit

* andere Nennweite auf Anfrage

* other nominal sizes on request

DN	L	H ₁		PN25	PN40	B	PN 25						PN 40						f	D ₁	Br. okr. / Otvoranje Umdr. / Hub. Turns / lift	m
		Zatvoreno Geschlossen Closed	Otvoreno Offen Open	H ₂			D	k	d ₁	l	n	b	D	k	d ₁	l	n	b				
40	240	420	480	80	80	160	150	110	84	19	4	19	150	110	84	19	4	19	3	200	11	23
50	250	440	510	87,5	87,5	180	165	125	99	19	4	19	165	125	99	19	4	19	3	225	13	30
65	270	490	580	97,5	97,5	215	185	145	118	19	8	19	185	145	118	19	8	19	3	280	18	45
80	280	510	610	105	105	235	200	160	132	19	8	19	200	160	132	19	8	19	3	280	21	50
100	330	600	720	122,5	122,5	280	235	190	156	23	8	19	235	190	156	23	8	19	3	320	25	72
125	360	705	850	140	140	315	270	220	184	28	8	19	270	220	184	28	8	23,5	3	360	24	111
150	390	775	950	155	155	340	300	250	211	28	8	20	300	250	211	28	8	26	3	360	28	140
200	460	970	1200	190	197,5	420	360	310	274	28	12	22	375	320	284	31	12	30	3	400	37	220
250	530	1165	1440	222,5	235	500	425	370	330	31	12	24,5	450	385	345	34	12	34,5	3	500	39	270
300	630	1250	1600	252,5	267,5	580	485	430	389	31	16	27,5	515	450	409	34	16	39,5	4	640	46	430
350	690	1390	1780	287,5	300	620	555	490	448	34	16	30	580	510	465	37	16	44	4	640	54	530
400	750	1630	2070	320	340	690	620	550	503	37	16	32	660	585	535	41	16	48	4	720	54	730
500	880	1900	2430	375	387,5	840	730	660	609	37	20	36,5	755	670	615	44	20	52	4	800	59	1250
600	1000	2200	2850	432,5	455	980	845	770	720	41	20	42	890	795	735	50	20	58	5	800	72	1830
700	1130	2500	3250	490	-	1060	960	875	820	44	24	46,5	-	-	-	-	-	-	5	800	75	2420
800	1250	2900	3750	552,5	-	1200	1085	990	928	50	24	51	-	-	-	-	-	-	5	900	86	3400
1000	1500	3420	4450	670	-	1460	1320	1210	1140	57	28	60	-	-	-	-	-	-	5	900	105	5280

* ostali profili na upit

* andere Nennweite auf Anfrage

* other nominal sizes on request

