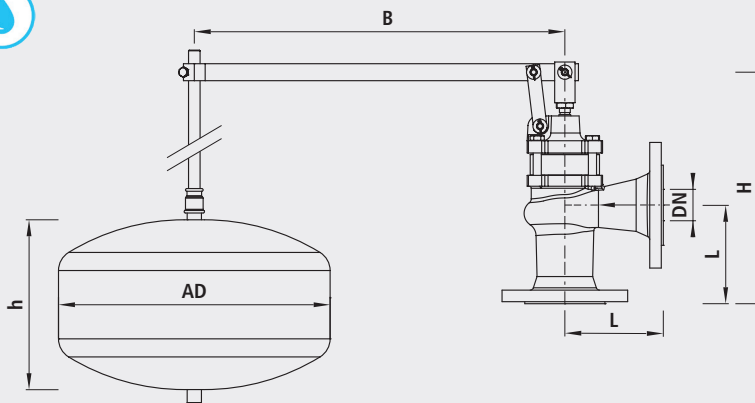

Mechanical float valve, corner, PN 10

1611

**Application**

- for drinking water -10° to +40°C
- Water level adjustment inside the reservoir

Characteristics

- The valve is controlled mechanically directly via a float with float arms.
- Admission pressure max. 10 bar
- Corner model

Installation and assembly

- A shut-off valve and a pressure-reducing valve should be used in front of the valve.
- The float can be mounted at a rotation of 90°

Material

- Seat seal: EPDM
- Valve and float: Epoxy-coated
- Guide sleeve: Brass

Artikel-Nr.	DN	PN	L	B	H	AD	h	KVS l/min.	kg
1611040000	40	10	115	700	262	350	200	516	15.000
1611050000	50	10	125	700	277	350	200	833	20.000
1611065000	65	10	145	700	341	400	250	1300	26.000
1611080000	80	10	155	800	352	400	250	1500	29.000