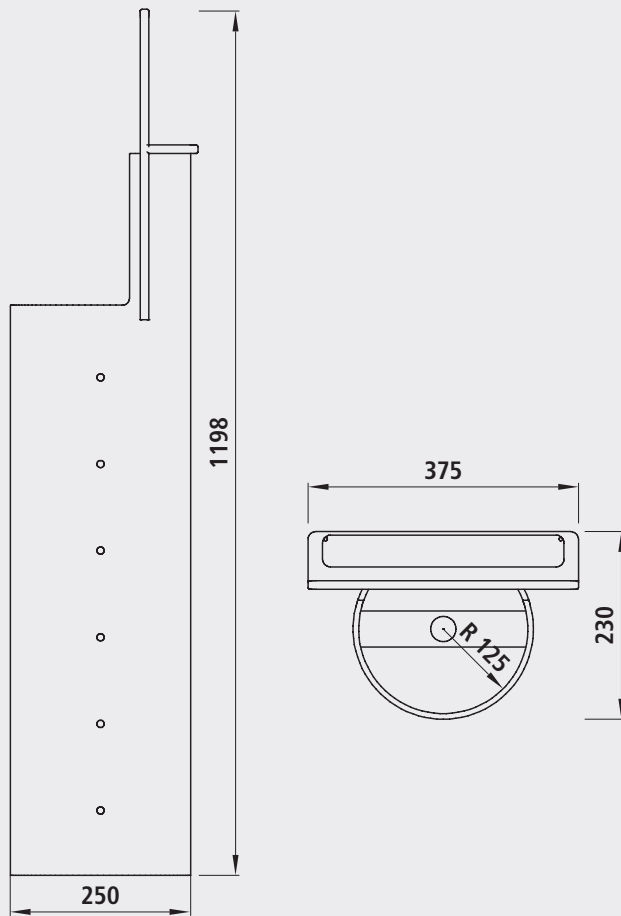

Float protection pipe

1699

**Application**

- The float protection pipe is used wherever the filling of a tank results in significant changes in the water level, which could prevent the float control system from working properly. In addition, the float rod is guided. The control valves are mounted on the drilled bracket.

Installation and assembly

- The float protection pipe is delivered with pipe clamps and anchor bolts for the assembly.
- Variants:
 - Float protection pipe without assembly set (No. 1699900010)
 - Float bracket (No° 1943800005) for On/Off valve (No. 1600)
 - Float bracket (No° 1943800006) for float valve (No. 1601)

Material

- PE

Artikel-Nr.	kg
1699V00010	11.000