

NAZIVNI PROMJER NENNWEITE NOMINAL SIZE	NAZIVNI TLAK NENNDRUCK PRESSURE RATING	PRIRUBNICE FLANSHE FLANGES EN 1092-2	VODNI ISPITNI TLAK WASSERPRÜFDRUCK HIDROSTATIC TEST PRESSURE
DN	bar	PN	bar
700 - 1200	10	10	15
700 - 1200	16	16	24

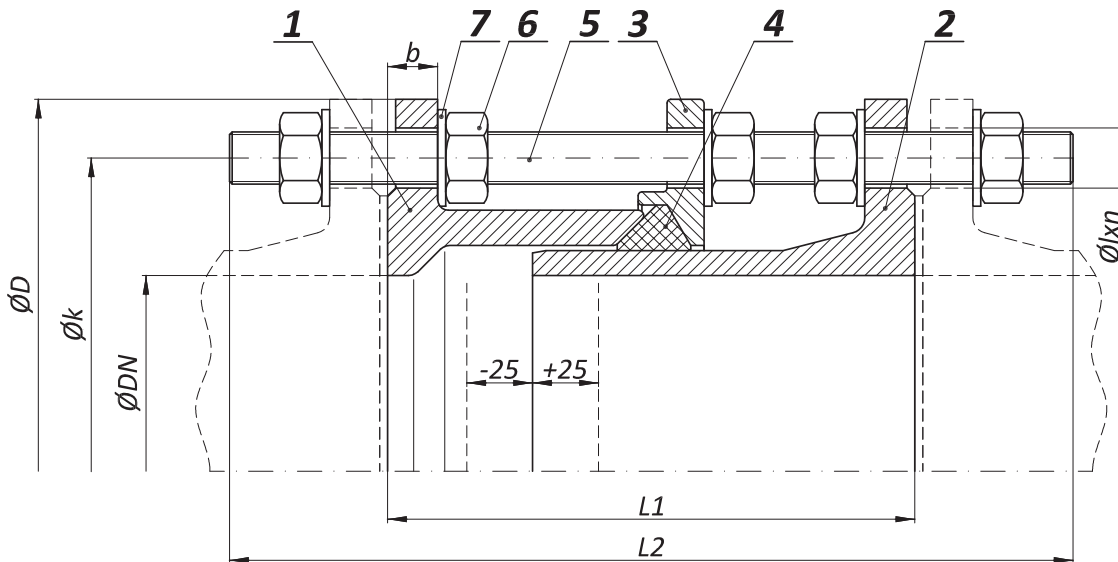

POZ TEIL PART	MATERIJAL PO EN-u WERKSTOFF NACH EN MATERIAL ACC TO EN
1	EN-GJS-400-15
2	EN-GJS-400-15
3	EN-GJS-400-15
4	EPDM
5	8.8 galv.
6	8 galv.
7	Galv.

Ostali materijali na upit  
Andere Werkstoffe auf Anfrage  
Other materials on request

**NAMJENA:** VODA, PITKA VODA, MORSKA VODA, NAFTA, OTPADNA VODA  
**VERWENDUNG:** WASSER, TRINKWASSER, SEEWASSER, ÖL, ABWASSER  
**APPLICATION:** WATER, POTABLE WATER, SEA WATER, OIL, WASTE WATER

**MAX. RADNA TEMPERATURA:** 60°C (ostalo na upit)  
**MAX. ARBEIT TEMPERATUR:** 60°C (Andere auf Anfrage)  
**MAX. WORKING TEMPERATURE:** 60°C (other on request)

Standardna površinska zaštita: plastificirano min. 250 mic RAL 5015  
Standard beschichtung: Pulverbeschichted min. 250 mic RAL 5015  
Standard coating: Fusion bonded epoxy powder min. 250 mic RAL 5015

Ostali mediji / aplikacije ili površinska zaštita na upit  
Andere Medium / Verwendung oder beschichtung auf Anfrage  
Other medium / application or coating on request

Prirubnice izvedene za ugradnju prema EN 1092-2 ili na zahtjev prema ostalim standardima.  
Einbaufansche nach EN 1092-2 oder auf Anfrage nach andere Standard.  
Installation flanges according to EN 1092-2 or on request according to other standard.

DN		700	800	900	1000	1200
PN 10	D	895	1015	1115	1230	1455
	k	840	950	1050	1160	1380
	n	24	24	28	28	32
	n <sub>1</sub>	8	12	14	14	16
	l	31	34	34	37	41
	b	32,5	35	37,5	40	45
	L <sub>1</sub>	260	290	290	290	360
	L <sub>2</sub>	410	460	470	490	600
	m (kg)	259	354	525	690	1100
PN 16	D	910	1025	1125	1255	1485
	k	840	950	1050	1170	1390
	n	24	24	28	28	32
	n <sub>1</sub>	8	12	14	14	16
	l	37	41	41	44	50
	b	39,5	43	46,5	50	57
	L <sub>1</sub>	300	320	320	340	360
	L <sub>2</sub>	480	520	520	560	600
	m (kg)	368	480	548	719	1110

Standardna dužina ugradnje. Na poseban zahtjev moguće su i druge dužine ugradnje.  
Standard – Baulägenreihe. Es ist möglich auf besondere Anforderung auch andere Baulägenreihe bestellen.  
Standard face to face. It is able to order other face to face.

L<sub>1</sub>

Broj rupa  
Anzahl der Löcher  
Number of holes

n

Broj navojnih šipki  
Anzahl der gewindestangen  
Number of threaded rods

n<sub>1</sub>